

**Pufferspeicher**  
**Buffer storage tanks**  
**Ballon tampon**  
**Accumulatori tampone**  
**PSM 300 – 5000**

**EnEV 730.02**  
**ErP 812/2013**  
**ErP 814/2013**  
**CE**

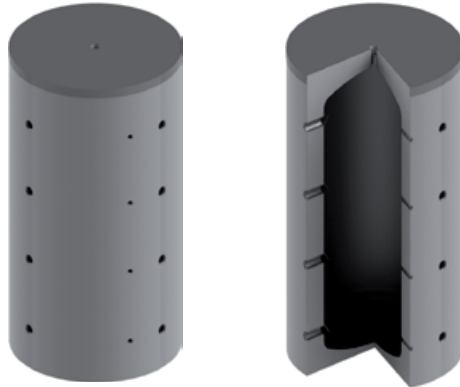

**Bauart**  
**Design | Structure | Struttura**

Die Speicher werden aus hochwertigem Stahl nach EN 10025 gefertigt.

**EN** The storage tanks are made from high quality steel in accordance with EN 10025.

**FR** Les ballons sont fabriqués en acier de grande qualité, selon la norme EN 10025.

**IT** Gli accumulatori sono realizzati in acciaio pregiato secondo la norma EN 10025.

<b>Betriebsdruck / Prüfdruck</b> Operating pressure / test pressure   Pression de service / Pression test   Pressione d'esercizio / Pressione di collaudo	3 bar / 4.5 bar
<b>Einsatzgebiet</b> Application   Application   Applicazione	18°C – 95°C

**Lieferumfang**  
**Delivery | Livraison | Consegna**

<b>Bedienungsanleitung</b> Operation manual   Mode d'emploi   Istruzioni per l'uso	1 x
---	-----

**Schutz vor Korrosion**  
**Anti-corrosion protection | Protection contre la corrosion | Protezione anticorrosiva**

Innen sind die Speicher unbehandelt. Aussen sind die Speicher mit einem Antikorrosionslack lackiert.

**EN** The storage tanks are untreated on the interior. The storage tanks are externally coated with a corrosion-protection paint.

**FR** À l'intérieur, les réservoirs ne sont pas traités. À l'extérieur, les réservoirs sont recouverts d'une laque anticorrosion.

**IT** L'interno degli accumulatori non è trattato. Gli accumulatori sono verniciati all'esterno con uno smalto resistente alla corrosione.

	Verwendung Usage   Utilisation   Uso	300	500	600	800	1000	1050	1250	1500	1600	1950	2000	2500	3000	4000	5000
TopShell 100	Wärmeverlust [kWh/24h] Heat losses   Pertes thermiques   Perdita di calore	2.06	2.61	2.89	3.12	3.38	3.49	3.82	-	-	-	-	-	-	-	-
	ErP-Label ErP class   Classe ErP   Classe ErP	C	C	C	C	C	C	C	(D)	(D)	-	-	-	-	-	-
	Zulassung CH Approval   Certification   Omologazione	X	X	•	•	•	•	•	X	X	X	X	X	X	X	X
	Zulassung EU Approval   Certification   Omologazione	•	•	•	•	•	•	•	X	X	•	•	•	•	•	•
	A $\overline{\Delta}$ [mm]	1400	1680	1700	1740	2090	2050	2060	2200	1900	2010	2420	2330	2770	2885	2920
	C Ø [mm]	750	850	900	990	990	1050	1150	1200	1300	1450	1300	1450	1450	1600	1800
	Art. Nr. 300106... Part no.   Réf.   Art.n.	0301	0501	0601	0801	1001	1051	1251	1501*	1601*	1951	2001	2501	3001	4001	5001
TopShell 130	Wärmeverlust [kWh/24h] Heat losses   Pertes thermiques   Perdita di calore	-	-	-	-	-	-	-	4.0	4.08	-	-	-	-	-	-
	ErP-Label ErP class   Classe ErP   Classe ErP	-	-	-	-	-	-	-	C	C	-	-	-	-	-	-
	Zulassung CH Approval   Certification   Omologazione	X	X	•	•	•	•	•	•	•	X	X	X	X	X	X
	Zulassung EU Approval   Certification   Omologazione	•	•	•	•	•	•	•	•	•	•	•	•	•	•	•
	A $\overline{\Delta}$ [mm]	1430	1710	1730	1770	2120	2080	2090	2230	1930	2040	2450	2360	2800	2915	2950
	C Ø [mm]	810	910	960	1050	1050	1110	1210	1260	1360	1510	1360	1510	1510	1660	1860
	Art. Nr. 300106... Part no.   Réf.   Art.n.	0302*	0502*	0602*	0802*	1002*	1052*	1252*	1502	1602	1952*	2002*	2502*	3002*	4002*	5002*
TopShell 160	Wärmeverlust [kWh/24h] Heat losses   Pertes thermiques   Perdita di calore	-	-	-	-	-	-	-	-	-	-	-	-	-	-	-
	ErP-Label ErP class   Classe ErP   Classe ErP	-	-	-	-	-	-	-	-	-	-	-	-	-	-	-
	Zulassung CH Approval   Certification   Omologazione	X	X	•	•	•	•	•	•	•	•	•	•	•	•	•
	Zulassung EU Approval   Certification   Omologazione	•	•	•	•	•	•	•	•	•	•	•	•	•	•	•
	A $\overline{\Delta}$ [mm]	1460	1740	1760	1800	2150	2110	2120	2260	1960	2070	2480	2390	2830	2945	2980
	C Ø [mm]	870	970	1020	1110	1110	1170	1270	1320	1420	1570	1420	1570	1570	1720	1920
	Art. Nr. 300106... Part no.   Réf.   Art.n.	0303*	0503*	0603*	0803*	1003*	1053*	1253*	1503*	1603*	1953	2003	2503	3003	4003	5003

\* Keine Lagerware. Lieferzeit 4–6 Wochen

Not in stock. Delivery time 4–6 weeks | Marchandise non stockée. Délai: 4 à 6 semaines | Merce non a magazzino. Tempistiche di consegna 4–6 settimane

Nicht zugelassen | None approved | Non agrée | Non omologato

Zugelassen (Empfohlene Isolierung)  
Approved (Recommended insulation) | Agrée (Isolation recommandée) | Omologato (Isolamento consigliato)

Zugelassen (oberhalb Mindestanforderung)  
Approved (Exceeds minimum requirements) | Agrée (Supérieure aux exigences minimales requises) | Omologato (Requisito minimo superiore)

Höhe  
Height | Hauteur | Altezza

**Pufferspeicher**  
**Buffer storage tanks**  
**Ballon tampon**  
**Accumulatori tampone**  
**PSM 300 – 5000**



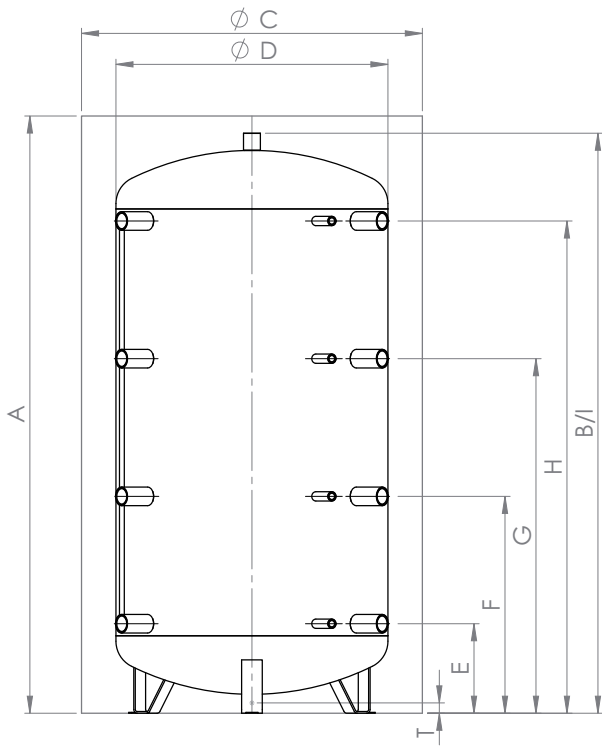



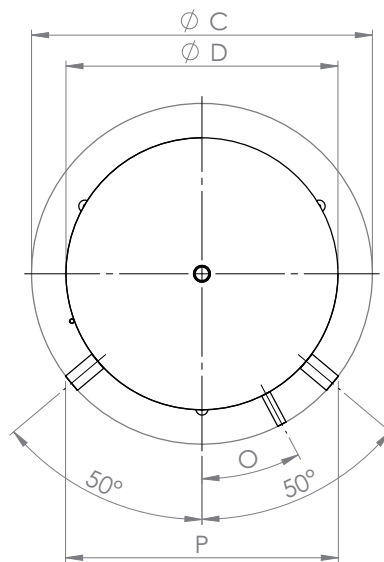



300 – 5000



300 – 5000



300 – 5000

Verwendung Usage Utilisation Uso	Dimension Dimension Dimensione	300	500	600	800	1000	1050	1250	1500	1600	1950	2000	2500	3000	4000	5000
<b>Inhalt</b> Capacity   Contenance   Contenuto	l	279	480	560	718	887	996	1266	1500	1555	2005	2021	2304	2852	3759	5003
<b>Kippmass</b> Tilted dimension   Cote de basculement   Altezza in raddrizzamento	mm	1385	1665	1690	1740	2085	2020	2070	2195	1930	2060	2420	2395	2780	2935	3035
<b>P Einbringmass</b> Delivery dimensions   Cote de mise en place   Ingombro	100 mm	610	690	740	800	800	850	950	1000	1100	1250	1100	1250	1250	1400	1600
	130 mm	660	740	780	840	840	890	970	1010	1100	1250	1100	1250	1250	1400	1600
	160 mm	710	780	820	890	890	930	1100	1050	1130	1250	1130	1250	1250	1400	1600
<b>B Höhe ohne Isolierung</b> Height without insulation   Hauteur sans isolation   Altezza senza isolamento	mm	1350	1630	1650	1690	2040	2000	2010	2150	1950	2060	2370	2280	2720	2835	2870
<b>D Ø ohne Isolierung</b> without insulation   sans isolation   senza isolamento	mm	550	650	700	790	790	850	950	1000	1100	1250	1100	1250	1250	1400	1600
<b>E* Anschluss 1</b> Connection   Raccord   Collegamento	 - mm	220	220	230	260	310	310	310	380	320	495	320	535	380	505	400
	G"	1 1/2"	1 1/2"	1 1/2"	1 1/2"	1 1/2"	1 1/2"	1 1/2"	1 1/2"	1 1/2"	2"	1 1/2"	2"	2"	2"	2"
	 - G"	1/2"	1/2"	1/2"	1/2"	1/2"	1/2"	1/2"	1/2"	1/2"	1/2"	1/2"	1/2"	1/2"	1/2"	1/2"
<b>F* Anschluss 2</b> Connection   Raccord   Collegamento	 - mm	470	620	610	630	745	745	745	825	740	875	900	975	1020	1110	1100
	G"	1 1/2"	1 1/2"	1 1/2"	1 1/2"	1 1/2"	1 1/2"	1 1/2"	1 1/2"	1 1/2"	2"	1 1/2"	2"	2"	2"	2"
	 - G"	1/2"	1/2"	1/2"	1/2"	1/2"	1/2"	1/2"	1/2"	1/2"	1/2"	1/2"	1/2"	1/2"	1/2"	1/2"
<b>G* Anschluss 3</b> Connection   Raccord   Collegamento	 - mm	800	1010	990	1030	1250	1250	1250	1350	1150	1255	1490	1415	1680	1860	1810
	G"	1 1/2"	1 1/2"	1 1/2"	1 1/2"	1 1/2"	1 1/2"	1 1/2"	1 1/2"	1 1/2"	2"	1 1/2"	2"	2"	2"	2"
	 - G"	1/2"	1/2"	1/2"	1/2"	1/2"	1/2"	1/2"	1/2"	1/2"	1/2"	1/2"	1/2"	1/2"	1/2"	1/2"
<b>H* Anschluss 4</b> Connection   Raccord   Collegamento	 - mm	1120	1390	1380	1430	1710	1710	1710	1760	1570	1635	2020	1855	2330	2410	2520
	G"	1 1/2"	1 1/2"	1 1/2"	1 1/2"	1 1/2"	1 1/2"	1 1/2"	1 1/2"	1 1/2"	2"	1 1/2"	2"	2"	2"	2"
	 - G"	1/2"	1/2"	1/2"	1/2"	1/2"	1/2"	1/2"	1/2"	1/2"	1/2"	1/2"	1/2"	1/2"	1/2"	1/2"
<b>I Anschluss oben</b> Connection above   Raccord du haut   Collegamento superiore	 - mm	1350	1630	1650	1690	2040	2050	2010	2150	1900	2010	2370	2280	2720	2835	2870
	G"	1 1/4"	1 1/4"	1 1/4"	1 1/4"	1 1/4"	1 1/4"	1 1/4"	1 1/4"	1 1/4"	1 1/4"	1 1/4"	1 1/4"	1 1/4"	1 1/4"	1 1/4"
<b>T Bodenmuffe</b> Ground fitting   Manchon de fond   Manicotto a pavimento	 - mm	-	-	-	-	-	-	-	-	-	110	-	110	100	75	50
	G"	-	-	-	-	-	-	-	-	-	1 1/4"	-	1 1/4"	1 1/4"	1 1/4"	1 1/4"
<b>O Anordnung Fühler</b> Positioning sensor   Disposition sonde   Disposizione sensore	°	18.5	23.5	28.0	28.0	28.0	29.8	32.0	33.0	34.5	36.0	34.5	36.0	36.0	37.5	39.0
<b>Gewicht</b> Weight   Poids   Peso	kg	55	74	80	92	106	112	155	165	170	223	198	236	282	361	428
<b>Art.Nr. 100 mm</b> Part no.   Réf.   Art.n.	200103...	0301	0501	0601	0801	1001	1051	1251	1501	1601	1951	2001	2501	3001	4001	5001
<b>Art.Nr. 130 mm</b> Part no.   Réf.   Art.n.	200103...	0302	0502	0602	0802	1002	1052	1252	1502	1602	1952	2002	2502	3002	4002	5002
<b>Art.Nr. 160 mm</b> Part no.   Réf.   Art.n.	200103...	0303	0503	0603	0803	1003	1053	1253	1503	1603	1953	2003	2503	3003	4003	5003
<b>Elektroheizung zum Einschrauben*</b> Screw-in Immersion heater*   Résistances à visser*   Resistenza elettrica da avvitare*	bis kW to   à   a	4.5	6.0	7.5	9.0	9.0	9.0	9.0	9.0	9.0	9.0	9.0	9.0	9.0	9.0	9.0

\*Einbaumöglichkeit: 1 x Elektroheizung zum Einschrauben  
Installation option: 1 x Screw-in Immersion heater | Option d'installation: 1 x Résistances à visser | Opzione di installazione: 1 x Resistenza elettrica da avvitare

 Höhe  
Height | Hauteur | Altezza

 Fühler  
Sensor | Sonde | Sensore