

Pufferspeicher
Buffer storage tanks
Ballon tampon
Accumulatori tampone
PSRR 500 – 600

EnEV 730.02
ErP 812/2013
ErP 814/2013
CE

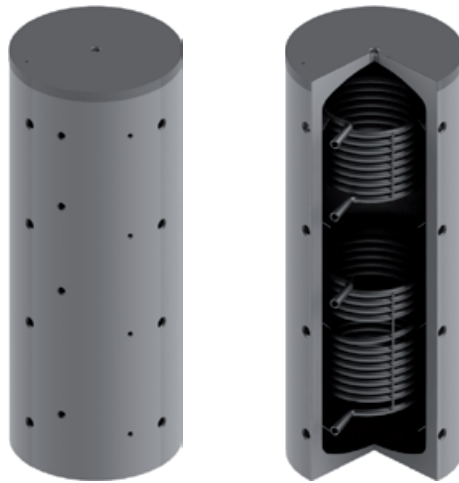

Bauart
Design | Structure | Struttura

Die Speicher werden aus hochwertigem Stahl nach EN 10025 gefertigt.

EN The storage tanks are made from high quality steel in accordance with EN 10025.

FR Les ballons sont fabriqués en acier de grande qualité, selon la norme EN 10025.

IT Gli accumulatori sono realizzati in acciaio pregiato secondo la norma EN 10025.

Betriebsdruck / Prüfdruck Operating pressure / test pressure Pression de service / Pression test Pressione d'esercizio / Pressione di collaudo	3 bar / 4.5 bar
Einsatzgebiet Application Application Applicazione	18°C – 95°C

Lieferumfang
Delivery | Livraison | Consegna

Bedienungsanleitung Operation manual Mode d'emploi Istruzioni per l'uso	1 x
---	-----



Schutz vor Korrosion

Anti-corrosion protection | Protection contre la corrosion | Protezione anticorrosiva

Innen sind die Speicher unbehandelt. Aussen sind die Speicher mit PU-Schaum fix geschäumt.

EN The storage tanks are untreated on the interior. On the exterior the storage tanks are foamed with polyurethane foam.

FR À l'intérieur, les réservoirs ne sont pas traités. À l'extérieur, ils sont recouverts de mousse fixe.

IT L'interno degli accumulatori non è trattato. All'esterno gli accumulatori presentano una copertura di schiuma PU fissa.

Wärmetauscher

Heat exchanger | Échangeur de chaleur | Scambiatore di calore

Ein eingeschweisster grossflächiger Wärmetauscher.

EN One welded large-surface heat exchanger.

FR Un échangeur de chaleur grande surface soudé.

IT Uno scambiatore di calore saldato di grande superficie.

Isolierung

Insulation | Isolation | Isolamento

PU-Hartschaum

60 mm PU-Hartschaum fix geschäumt. Skaimantel 5 mm mit Reissverschluss vormontiert, inklusive Rosetten und Abdeckhaube. Brandschutzklasse B2. Silber. Weitere Farben nach Absprache.

EN Rigid polyurethane foam
60 mm rigid polyurethane foam. Skai jacket 5 mm with zip preassembled, including cover plates and hood. Fire-resistance rating B2. Silver. Other colours on request.

FR Mousse solidifiée PU
60 mm de mousse dure PU Enveloppe en skai de 5 mm préinstallée avec fermeture à glissière, y compris rosettes et capot. Classe allemande de protection incendie B2. Argent. Autres couleurs après concertation.

IT Schiuma PU rigida
60 mm di schiuma rigida di poliuretano fissa. Mantello in skai da 5 mm pre-assemblato con cerniera, dotato di rosette e calotta di copertura. Classe di resistenza antincendio B2. Argento. Altri colori su richiesta.

≤ 600 L
PU-Hartschaum

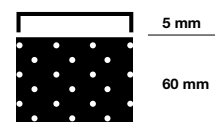

Pufferspeicher
Buffer storage tanks
Ballon tampon
Accumulatori tampone
PSRR 500 – 600



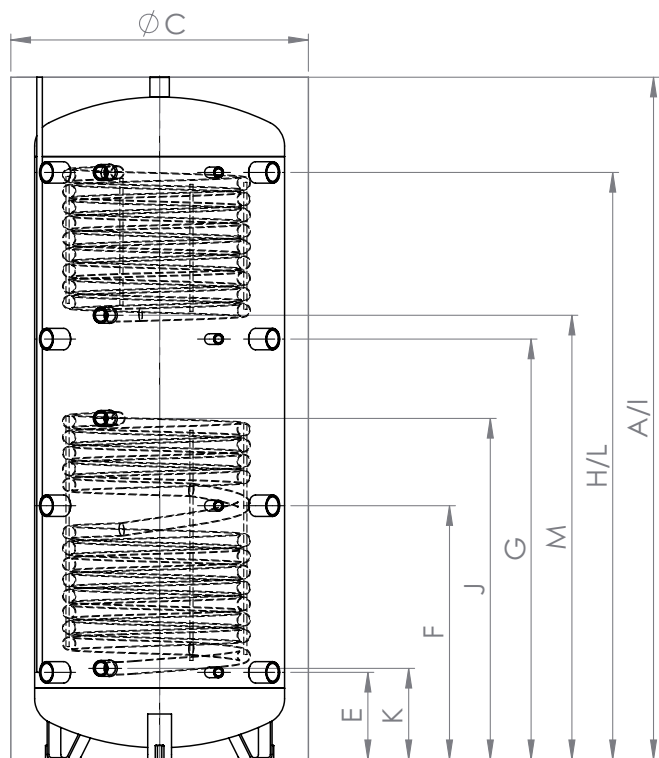



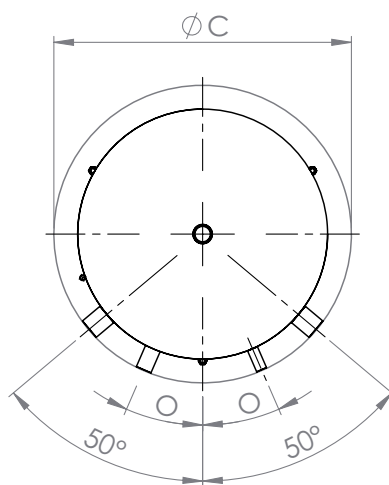





500 – 600



500 – 600



500 – 600

	Verwendung Usage Utilisation Uso	Dimension Dimension Dimension Dimensione	500	600
	Inhalt Capacity Contenance Contenuto	l	479	559
	Glattrohrwärmetauscher unten Bottom heating coil Échangeurs de chaleur bas Serpentino inferiore	m ²	1.9	1.9
		l	12.5	12.5
	Glattrohrwärmetauscher oben Top heating coil Échangeurs de chaleur haut Serpentino superiore	m ²	1.4	1.4
		l	9.2	9.2
	Kippmass Tilted dimension Cote de basculement Altezza in raddrizzamento	mm	1880	2120
A	Höhe mit Isolierung Height with insulation Hauteur avec isolation Altezza con isolamento	mm	1720	1980
C	Ø mit Isolierung with insulation avec isolation con isolamento	mm	750	750
E*	Anschluss 1 Connection Raccord Collegamento	 – mm	220	220
		G"	1 ½"	1 ½"
		 – G"	½"	½"
F*	Anschluss 2 Connection Raccord Collegamento	 – mm	640	730
		G"	1 ½"	1 ½"
		 – G"	½"	½"
G*	Anschluss 3 Connection Raccord Collegamento	 – mm	1060	1230
		G"	1 ½"	1 ½"
		 – G"	½"	½"
H*	Anschluss 4 Connection Raccord Collegamento	 – mm	1480	1740
		G"	1 ½"	1 ½"
		 – G"	½"	½"
I	Anschluss oben Connection above Raccord du haut Collegamento superiore	 – mm	1720	1980
		G"	1 ¼"	1 ¼"
J	VL Glattrohrwärmetauscher unten Bottom heating coil Échangeurs de chaleur bas Serpentino inferiore	 – mm	860	950
		G"	1"	1"
K	RL Glattrohrwärmetauscher unten Bottom heating coil Échangeurs de chaleur bas Serpentino inferiore	 – mm	230	320
		G"	1"	1"
L	VL Glattrohrwärmetauscher oben Top heating coil Échangeurs de chaleur haut Serpentino superiore	 – mm	1480	1740
		G"	1"	1"
M	RL Glattrohrwärmetauscher oben Top heating coil Échangeurs de chaleur haut Serpentino superiore	 – mm	1120	1380
		G"	1"	1"
	ErP-Klasse ErP class Classe ErP Classe ErP		B	B
	Gewicht Weight Poids Peso	kg	101	125
	Art.Nr. Part no. Réf. Art.n.		0500	0600
	Elektroheizung zum Einschrauben* Screw-in Immersion heater* Résistances à visser* Resistenza elettrica da avvitare*	bis kW to à a	6.0	7.5

*Einbaumöglichkeit: 1 x Elektroheizung zum Einschrauben
Installation option: 1 x Screw-in Immersion heater | Option d'installation: 1 x Résistances à visser | Opzione di installazione: 1 x Resistenza elettrica da avvitare



Höhe
Height | Hauteur | Altezza



Fühler
Sensor | Sonde | Sensore