

Pufferspeicher für Wärmepumpe
Buffer storage tanks for heat pump
Ballon tampon pour pompe à chaleur
Accumulatori tampone per pompa di calore
PUF 200 – 600

EnEV 730.02
ErP 812/2013
ErP 814/2013
CE

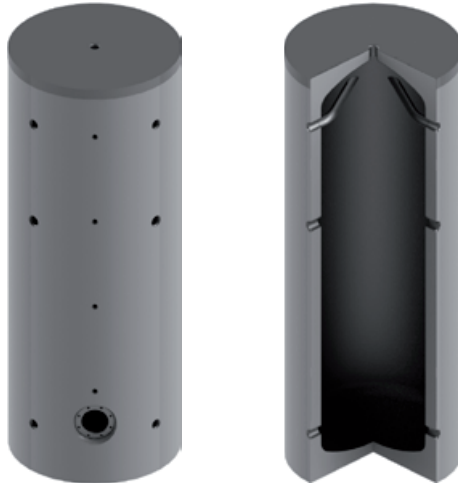

Bauart
Design | Structure | Struttura

Die Speicher werden aus hochwertigem Stahl nach EN 10025 gefertigt.

EN The storage tanks are made from high quality steel in accordance with EN 10025.

FR Les ballons sont fabriqués en acier de grande qualité, selon la norme EN 10025.

IT Gli accumulatori sono realizzati in acciaio pregiato secondo la norma EN 10025.

Betriebsdruck / Prüfdruck Operating pressure / test pressure Pression de service / Pression test Pressione d'esercizio / Pressione di collaudo	3 bar / 4.5 bar
Einsatzgebiet Application Application Applicazione	18°C – 95°C

Lieferumfang
Delivery | Livraison | Consegna

Bedienungsanleitung Operation manual Mode d'emploi Istruzioni per l'uso	1 x
---	-----



Schutz vor Korrosion

Anti-corrosion protection | Protection contre la corrosion | Protezione anticorrosiva

Innen sind die Speicher unbehandelt. Aussen sind die Speicher mit PU-Schaum fix geschäumt.

EN The storage tanks are untreated on the interior. On the exterior the storage tanks are foamed with polyurethane foam.

FR À l'intérieur, les réservoirs ne sont pas traités. À l'extérieur, ils sont recouverts de mousse fixe.

IT L'interno degli accumulatori non è trattato. All'esterno gli accumulatori presentano una copertura di schiuma PU fissa.

Isolierung

Insulation | Isolation | Isolamento

PU-Hartschaum

60 mm PU-Hartschaum fix geschäumt. Skaimantel 5 mm mit Reissverschluss vormontiert, inklusive Rosetten und Abdeckhaube. Brandschutzklasse B2. Silber. Weitere Farben nach Absprache.

EN Rigid polyurethane foam

60 mm rigid polyurethane foam. Skai jacket 5 mm with zip preassembled, including cover plates and hood. Fire-resistance rating B2. Silver. Other colours on request.

FR Mousse solidifiée PU

60 mm de mousse dure PU Enveloppe en skai de 5 mm préinstallée avec fermeture à glissière, y compris rosettes et capot. Classe allemande de protection incendie B2. Argent. Autres couleurs après concertation.

IT Schiuma PU rigida

60 mm di schiuma rigida di poliuretano fissa. Mantello in skai da 5 mm pre-assemblato con cerniera, dotato di rosette e calotta di copertura. Classe di resistenza antincendio B2. Argento. Altri colori su richiesta.

≤ 600 L
PU-Hartschaum

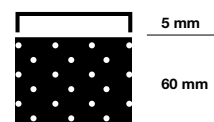

Pufferspeicher für Wärmepumpe
Buffer storage tanks for heat pump
Ballon tampon pour pompe à chaleur
Accumulatori tampone per pompa di calore
PUF 200 – 600



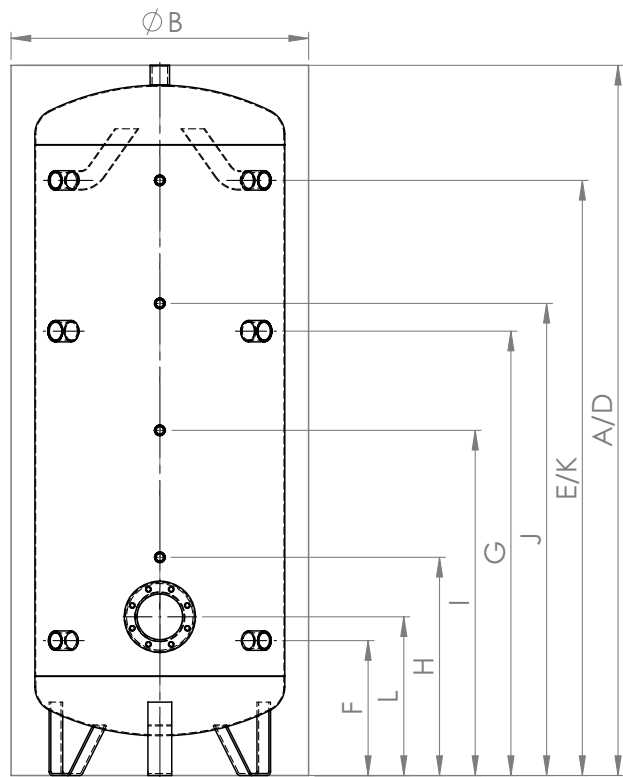



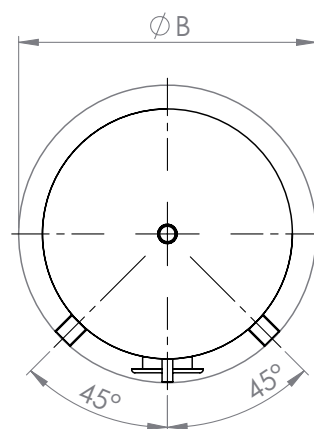



200 – 600



200 – 600



200 – 600

	Verwendung Usage Utilisation Uso	Dimension Dimension Dimension Dimensione	200	300	400	500	600
	Inhalt Capacity Contenance Contenuto	l	190	282	377	479	559
	Kippmass Tilted dimension Cote de basculement Altezza in raddrizzamento	mm	1360	1700	1680	1940	2140
A	Höhe mit Isolierung Height with insulation Hauteur avec isolation Altezza con isolamento	mm	1215	1570	1500	1790	2000
B	Ø mit Isolierung with insulation avec isolation con isolamento	mm	600	650	750	750	750
D	Vorlauf Supply Alimentation Mandata	 – mm	1215	1570	1500	1790	2000
		G"	1 ¼"	1 ¼"	1 ¼"	1 ¼"	1 ¼"
E	Vorlauf Supply Alimentation Mandata	 – mm	1000	1295	1210	1500	1760
		G"	1 ¼"	1 ¼"	1 ¼"	1 ¼"	1 ¼"
F	Rücklauf Return Retour Ritorno	 – mm	220	275	290	340	240
		G"	1 ¼"	1 ¼"	1 ¼"	1 ¼"	1 ¼"
G	Elektroheizung zum Einschrauben* Screw-in Immersion heater* Résistances à visser* Resistenza elettrica da avvitare*	 – mm	740	950	920	1120	1270
		G"	1 ½"	1 ½"	1 ½"	1 ½"	1 ½"
H	Thermometer / Fühler Thermometer / Sensor Thermomètre / Sonde Termometro / Sensore	 – mm	430	515	520	550	470
		G"	½"	½"	½"	½"	½"
I	Thermometer / Fühler Thermometer / Sensor Thermomètre / Sonde Termometro / Sensore	 – mm	620	775	750	870	900
		G"	½"	½"	½"	½"	½"
J	Thermometer / Fühler Thermometer / Sensor Thermomètre / Sonde Termometro / Sensore	 – mm	810	1035	980	1190	1330
		G"	½"	½"	½"	½"	½"
K	Thermometer / Fühler Thermometer / Sensor Thermomètre / Sonde Termometro / Sensore	 – mm	1000	1295	1210	1500	1760
		G"	½"	½"	½"	½"	½"
L	Flansch Flange Bride Flangia	 – mm	290	340	350	400	300
		Ø – mm	180/120	180/120	180/120	180/120	180/120
	Isolierung Insulation Isolation Isolamento		60 mm fix eingeschäumt Fixed with foam Enrobage mousse fixe Schiuma rigida fissa				
	Wärmeverlust Heat losses Pertes thermiques Perdita di calore	kWh/24h	0.98	1.40	1.64	1.89	2.03
	ErP-Klasse ErP class Classe ErP Classe ErP		A	B	B	B	B
	Gewicht Weight Poids Peso	kg	46	61	70	80	91
	Art.Nr. Part no. Réf. Art.n.	200102...	0200	0300	0400	0500	0600
	*Einbaumöglichkeit: 1 x Elektroheizung zum Einschrauben Installation option: 1 x Screw-in Immersion heater Option d'installation: 1 x Résistances à visser Opzione di installazione: 1 x Resistenza elettrica da avvitare						
	 Höhe Height Hauteur Altezza						