

**Trinkwasserspeicher für Wärmepumpe**  
**Domestic hot water tank for heat pump**  
**Ballon eau chaude sanitaire pour pompe à chaleur**  
**Serbatoio di accumulo acqua calda sanitaria per pompa di calore**  
**WP/C 300 – 2000**

**Edelstahl**  
 Stainless steel | Acier inoxydable | Acciaio inossidabile

**DIN**

EN 12897  
 EnEV 730.02  
 ErP 812/2013  
 ErP 814/2013  
 DIN 4753

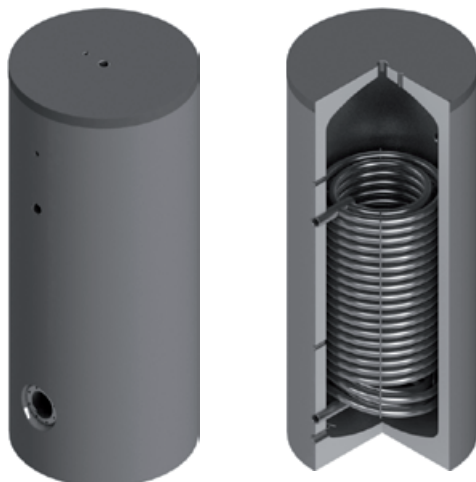

**Bauart**  
 Design | Structure | Struttura

Die Speicher sind aus hochwertigem Edelstahl V4A gefertigt.  
 Die Speicher werden nach EN 12897:2014 dimensioniert, gefertigt und zertifiziert.

**EN** The storage tanks are made from high quality stainless steel (V4A). The storage tanks are designed, manufactured and certified in accordance with EN 12897:2014.

**FR** Les ballons sont fabriqués en acier inoxydable au molybdène de grande qualité. Les ballons sont dimensionnés, fabriqués et certifiés selon la norme EN 12897:2014.

**IT** Gli accumulatori sono realizzati in pregiato acciaio inossidabile V4A. Gli accumulatori sono dimensionati, costruiti e certificati secondo la norma EN 12897:2014.

**Lieferumfang**  
 Delivery | Livraison | Consegna

	l	mm		Art. Nr.
<b>Bedienungsanleitung</b> Operation manual   Mode d'emploi   Istruzioni per l'uso			1 x	
<b>Thermometer mit Tauchhülse</b> Thermometer with immersion sleeve   Thermomètre avec manchon d'immersion   Termometro con manicotto ad immersione	≤ 600	100	1 x	6001160100
	≥ 800	200	1 x	6001160200
<b>Tauchhülse</b> Immersion sleeve   Manchon d'immersion   Manicotto ad immersione		1000	1 x	6001191011



## Schutz vor Korrosion

Anti-corrosion protection | Protection contre la corrosion | Protezione anticorrosiva

Behälter vollständig tauchgebeizt und passiviert. Hochwertiger, dickwandiger Edelstahl V4A.

**EN** Water tanks completely pickled by immersion and passivated. High-quality stainless steel V4A with thick walls.

**FR** Réservoirs intégralement décapés par immersion et passivés. Tôle épaisse en acier inoxydable V4A haut de gamme.

**IT** Serbatoio interamente decapato a immersione e passivato. Pregiato acciaio inox V4A di notevole spessore.

## Wärmetauscher

Heat exchanger | Échangeur de chaleur | Scambiatore di calore

Ein eingeschweisster grossflächiger Wärmetauscher.

**EN** One welded large-surface heat exchanger.

**FR** Un échangeur de chaleur grande surface soudé.

**IT** Uno scambiatore di calore saldato di grande superficie.

## Isolierung

Insulation | Isolation | Isolamento

### PU-Hartschaum

60 mm PU-Hartschaum fix geschäumt. Skaimantel 5 mm mit Reissverschluss vormontiert, inklusive Rosetten und Abdeckhaube. Brandschutzklasse B2. Silber. Weitere Farben nach Absprache.

### UltraShell

Mehrschicht-Isolierung aus 80 mm Hartschaum + 20 mm Faservlies. PS-Mantel und Hakenleiste, inklusive Rosetten und Abdeckhaube. Brandschutzklasse B2. Silber. Lose geliefert.

### EN Rigid polyurethane foam

60 mm rigid polyurethane foam. Skai jacket 5 mm with zip preassembled, including cover plates and hood. Fire-resistance rating B2. Silver. Other colours on request.

### FR Mousse solidifiée PU

60 mm de mousse dure PU Enveloppe en skai de 5 mm préinstallée avec fermeture à glissière, y compris rosettes et capot. Classe allemande de protection incendie B2. Argent. Autres couleurs après concertation.

### IT Schiuma PU rigida

60 mm di schiuma rigida di poliuretano fissa. Mantello in skai da 5 mm pre-assemblato con cerniera, dotato di rosette e calotta di copertura. Classe di resistenza antincendio B2. Argento. Altri colori su richiesta.

### UltraShell

Multilayer insulation made of 80 mm rigid foam + 20 mm fibre fleece. PS jacket and hook rack, including cover plates and hood. Fire-resistance rating B2. Silver. Supplied loose.

### UltraShell

Isolation multicouches constituée de 80 mm de mousse dure + 20 mm de tissu fibreux. Enveloppe en PS équipée d'un support à crochets préinstallé, y compris rosettes et capot. Classe allemande de protection incendie B2. Argent. Livrée non montée.

### UltraShell

Isolamento multistrato con 80 mm di schiuma rigida + 20 mm di tessuto non tessuto. Mantello in PS e barra con ganci, rosette e calotta di copertura incluse. Classe di resistenza antincendio B2. Argento. Consegna sfusa.

≤ 600 L  
PU-Hartschaum

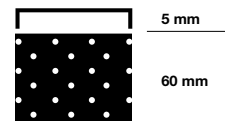

800 – 2000 L  
UltraShell

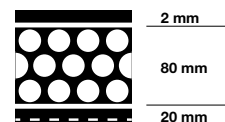

**Trinkwasserspeicher für Wärmepumpe**  
**Domestic hot water tank for heat pump**  
**Ballon eau chaude sanitaire pour pompe à chaleur**  
**Serbatoio di accumulo acqua calda sanitaria per pompa di calore**  
**WP/C 300 – 2000**

**Edelstahl**

Stainless steel | Acier inoxydable | Acciaio inossidabile

Typ WP/C		300	400	500	600	800	1000	1250	1500	1750	2000
Inhalt Capacity   Contenance   Contenuto	l	304	408	498	562	830	925	1226	1413	1728	1926
Ø mit Isolierung with insulation   avec isolation   con isolamento	mm	650	750	750	750	990	990	1100	1200	1300	1300
Ø ohne Isolierung without insulation   sans isolation   senza isolamento	mm	-	-	-	-	790	790	900	1000	1100	1100
Höhe mit Isolierung Height with insulation   Hauteur avec isolation   Altezza con isolamento	mm	1570	1500	1800	2000	1990	2190	2240	2120	2150	2350
Kippmass Tilted dimension   Cote de basculement   Altezza in raddrizzamento	mm	1700	1680	1950	2140	1990	2190	2260	2120	2200	2355
Betriebsdruck Heizung Heater operating pressure   Pression de service du chauffage   Pressione d'esercizio riscaldamento	bar	6	6	6	6	6	6	6	6	6	6
Betriebsdruck Wasser Water operating pressure   Pression de service de l'eau   Pressione d'esercizio acqua	bar	6	6	6	6	6	6	6	6	6	6
Prüfdruck Test pressure   Pression test   Pressione di collaudo	bar	12	12	12	12	12	12	12	12	12	12
max. Betriebstemperatur max. operating temperature   Temp. de service max.   Temperatura max. d'esercizio	°C	95	95	95	95	95	95	95	95	95	95
Gewicht Weight   Poids   Peso	kg	139	171	205	217	269	284	362	390	441	462
Art.Nr. Part no.   Réf.   Art.n.	100204...	0300	0400	0500	0600	0800	1000	1250	1500	1750	2000
<b>Isolierung</b> Insulation   Isolation   Isolamento		<b>60 mm fix eingeschäumt</b> Fixed with foam   Enrobage mousse fixe   Schiuma rigida fissa				<b>UltraShell 100</b>					
Wärmeverlust Heat losses   Pertes thermiques   Perdita di calore	kWh/24h	1.40	1.64	1.89	2.03	3.26	3.44	3.6	3.77	4.01	4.38
ErP-Klasse ErP class   Classe ErP   Classe ErP		B	B	B	B	C	C	C	C	C	C
Gewicht Weight   Poids   Peso	kg	-	-	-	-	35	40	45	50	55	60
Art.Nr. Part no.   Réf.   Art.n.	300104...	-	-	-	-	0809	1009	1259	1509	1759	2009



Typ WP/C		300	400	500	600	800	1000	1250	1500	1750	2000
<b>Glattrohrwärmetauscher</b> Heating coil   Échangeurs de chaleur   Serpentino	m <sup>2</sup>	3.4	4.7	6.1	6.1	6.0	6.0	8.2	9.0	10.3	10.3
<b>Inhalt Glattrohrwärmetauscher</b> Heating coil capacity   Contenance échangeurs de chaleur   Contenuto serpentino	l	21.7	30.6	39.8	39.8	39.2	39.2	68.3	75.4	86.7	86.7
<b>Durchflussmenge</b> Throughput   Débit   Portata flusso	m <sup>3</sup> / h	1.0	1.0	1.3	1.3	1.3	1.3	1.8	2.0	2.3	2.3
<b>Druckverlust</b> Pressure loss   Perte de charge   Perdita di pressione	mbar	10	10	20	20	20	20	10	20	30	30
<b>Dauerleistung</b> Continuous output   Régime permanent   Potenza continua 10°C / 45°C / 50°C	l / h	209	277	368	368	368	368	528	565	638	638
<b>max. Glattrohrwärmetauscherleistung</b> max. heating coil output   Puissance max. du échangeurs de chaleur   Potenza max. serpentino	kW	9.0	12.0	15.0	15.0	15.0	15.0	21.0	23.0	26.0	26.0
<b>Durchflussmenge</b> Throughput   Débit   Portata flusso	m <sup>3</sup> / h	5.7	7.9	10.0	10.0	10.0	10.0	13.8	15.9	17.0	17.0
<b>Druckverlust</b> Pressure loss   Perte de charge   Perdita di pressione	mbar	150	380	660	660	660	660	400	430	730	730
<b>Dauerleistung</b> Continuous output   Régime permanent   Potenza continua 10°C / 45°C / 80°C	l / h	1627	2249	2919	2919	2871	2871	3924	4307	4929	4929
<b>max. Glattrohrwärmetauscherleistung</b> max. heating coil output   Puissance max. du échangeurs de chaleur   Potenza max. serpentino	kW	66.2	91.6	118.8	118.8	116.9	116.9	159.7	175.3	200.6	200.6

**Trinkwasserspeicher für Wärmepumpe**  
**Domestic hot water tank for heat pump**  
**Ballon eau chaude sanitaire pour pompe à chaleur**  
**Serbatoio di accumulo acqua calda sanitaria per pompa di calore**  
**WP/C 300 – 2000**

**Edelstahl**  
 Stainless steel | Acier inoxydable | Acciaio inossidabile

300 – 600

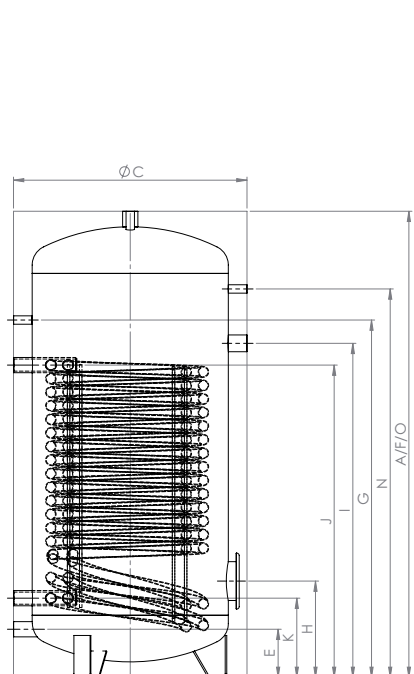

300 – 400

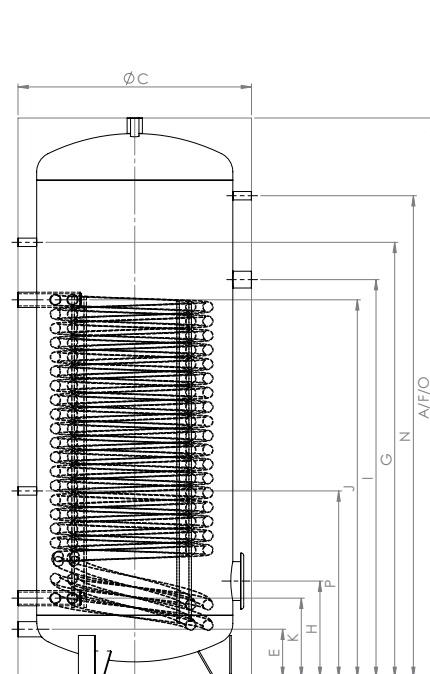

500

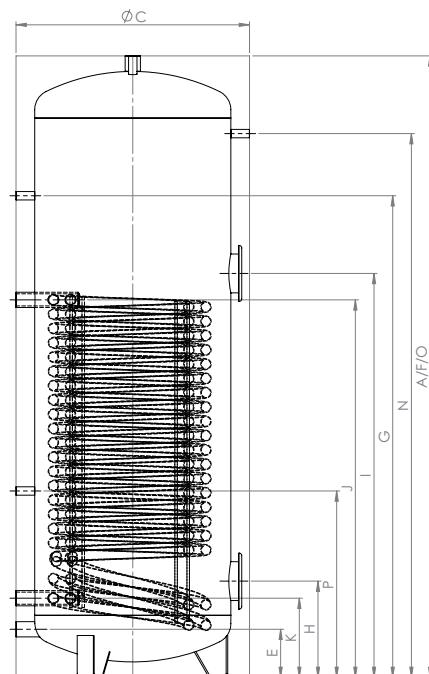

600

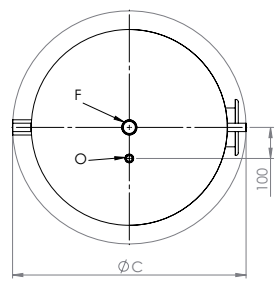

300 – 600



	Verwendung Usage Utilisation Uso	Dimension Dimension Dimension Dimensione	300	400	500	600
A	Höhe Height   Hauteur   Altezza	○ – mm	1570	1500	1800	2000
C	Ø	○ – mm	650	750	750	750
E	Kaltwasser Cold water   Eau froide   Acqua fredda	⇕ – mm	140	155	155	155
		G" – mm	1 ¼"	1 ¼"	1 ¼"	1 ¼"
F	Warmwasser Hot water   Eau chaude   Acqua calda	⇕ – mm	1570	1500	1800	2000
		G" – mm	1 ¼"	1 ¼"	1 ¼"	1 ¼"
G	Zirkulation Circulation   Circulation   Circolazione	⇕ – mm	1200	1150	1400	1550
		G" – mm	½"	½"	½"	½"
H	Flansch unten Flange below   Bride du bas   Flangia inferiore	⇕ – mm	295	310	310	310
		Ø – mm	180/120	180/120	180/120	180/120
I	Flansch oben / Muffe E-Heizung Flange above / Sleeve electric heater   Bride du haut / Manchon chauffage électrique   Flangia superiore / Manicotto riscaldatore elettrico	⇕ – mm	990	1075	1280	1300
		Ø – mm	1 ½"	1 ½"	1 ½"	180/120
J	VL Glattrohrwärmetauscher Heating coil   Échangeurs de chaleur   Serpentino	⇕ – mm	920	1005	1215	1215
		G" – mm	1 ¼"	1 ¼"	1 ¼"	1 ¼"
K	RL Glattrohrwärmetauscher Heating coil   Échangeurs de chaleur   Serpentino	⇕ – mm	240	255	255	255
		G" – mm	1 ¼"	1 ¼"	1 ¼"	1 ¼"
N	Thermometer Thermometer   Thermomètre   Termometro	⇕ – mm	1350	1250	1550	1750
		G" – mm	½"	½"	½"	½"
O	Fühlerhülse Sensor sleeve   Manchon de sonde   Manicotto sensore	⇕ – mm	1570	1500	1800	2000
		G" – mm	½"	½"	½"	½"
P	Fühler Sensor   Sonde   Sensor	⇕ – mm	-	-	600	600
		G" – mm	-	-	½"	½"

**Trinkwasserspeicher für Wärmepumpe**  
**Domestic hot water tank for heat pump**  
**Ballon eau chaude sanitaire pour pompe à chaleur**  
**Serbatoio di accumulo acqua calda sanitaria per pompa di calore**  
**WP/C 300 – 2000**

**Edelstahl**  
 Stainless steel | Acier inoxydable | Acciaio inossidabile

800 – 2000

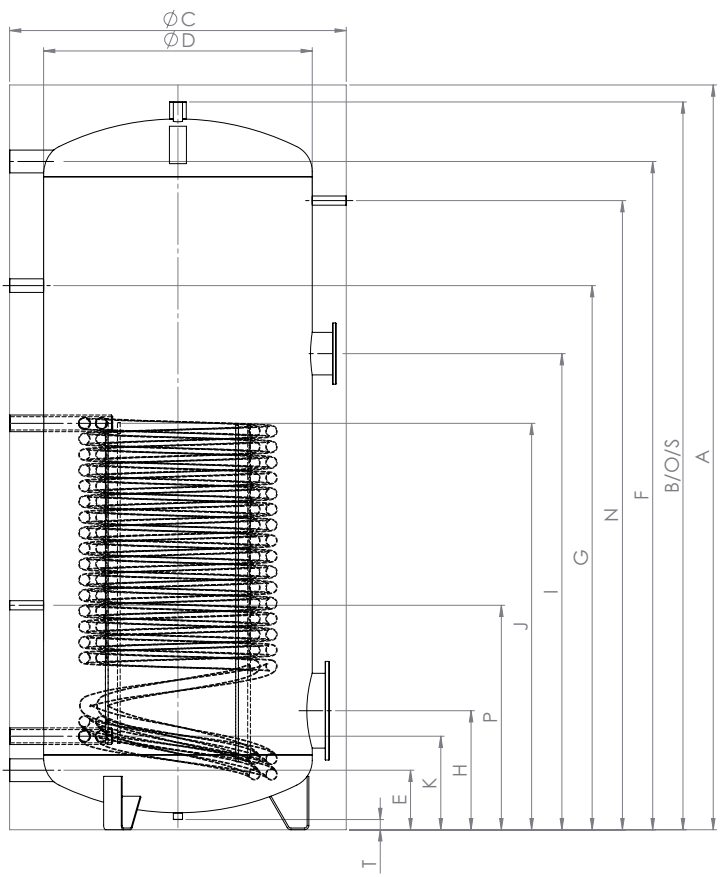

800 – 2000

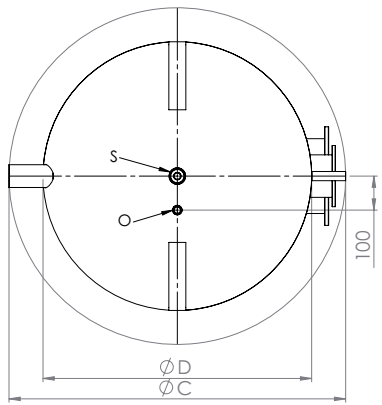

800 – 2000



	Verwendung Usage Utilisation Uso	Dimension Dimension Dimension Dimensione	800	1000	1250	1500	1750	2000
A	Höhe Height   Hauteur   Altezza	⊙ – mm	1990	2190	2240	2120	2150	2350
B		○ – mm	1940	2140	2190	2070	2100	2300
C	Ø	⊙ – mm	990	990	1100	1200	1300	1300
D		○ – mm	790	790	900	1000	1100	1100
E	Kaltwasser Cold water   Eau froide   Acqua fredda	⇕ – mm	175	175	200	220	235	235
		G" – mm	2"	2"	2"	2"	2"	2"
F	Warmwasser Hot water   Eau chaude   Acqua calda	⇕ – mm	1765	1965	1990	1730	1730	1930
		G" – mm	2"	2"	2"	2"	2"	2"
G	Zirkulation Circulation   Circulation   Circolazione	⇕ – mm	1400	1600	1600	1450	1500	1650
		G" – mm	1"	1"	1"	1"	1"	1"
H	Flansch unten Flange below   Bride du bas   Flangia inferiore	⇕ – mm	350	350	400	470	480	480
		Ø – mm	290/220	290/220	290/220	290/220	290/220	290/220
I	Flansch oben Flange above   Bride du haut   Flangia superiore	⇕ – mm	1400	1400	1400	1400	1420	1500
		Ø – mm	180/120	180/120	180/120	180/120	180/120	180/120
J	VL Glatrohrwärmetauscher Heating coil   Échangeurs de chaleur   Serpentino	⇕ – mm	1195	1195	1320	1310	1310	1310
		G" – mm	1 ¼"	1 ¼"	1 ½"	1 ½"	1 ½"	1 ½"
K	RL Glatrohrwärmetauscher Heating coil   Échangeurs de chaleur   Serpentino	⇕ – mm	275	275	320	360	360	360
		G" – mm	1 ¼"	1 ¼"	1 ½"	1 ½"	1 ½"	1 ½"
N	Thermometer Thermometer   Thermomètre   Termometro	⇕ – mm	1650	1850	1900	1750	1750	1950
		G" – mm	½"	½"	½"	½"	½"	½"
O	Fühlerhülse Sensor sleeve   Manchon de sonde   Manicotto sensore	⇕ – mm	1940	2140	2190	2070	2100	2300
		G" – mm	½"	½"	½"	½"	½"	½"
P	Fühler Sensor   Sonde   Sensor	⇕ – mm	660	660	680	590	600	600
		G" – mm	½"	½"	½"	½"	½"	½"
S	Anschluss oben Connection top   Lien ci-dessus   Collegamento sopra	⇕ – mm	1940	2140	2190	2070	2100	2300
		G" – mm	1 ¼"	1 ¼"	1 ¼"	1 ¼"	1 ¼"	1 ¼"
T	Bodenmuffe Ground fitting   Manchon de fond   Manicotto a pavimento	⇕ – mm	30	30	30	30	30	30
		G" – mm	½"	½"	½"	1 ¼"	1 ¼"	1 ¼"

⊙ mit Isolierung  
with insulation | avec isolation | con isolamento

○ ohne Isolierung  
without insulation | sans isolation | senza isolamento

⇕ Höhe  
Height | Hauteur | Altezza